

GO! TRACK

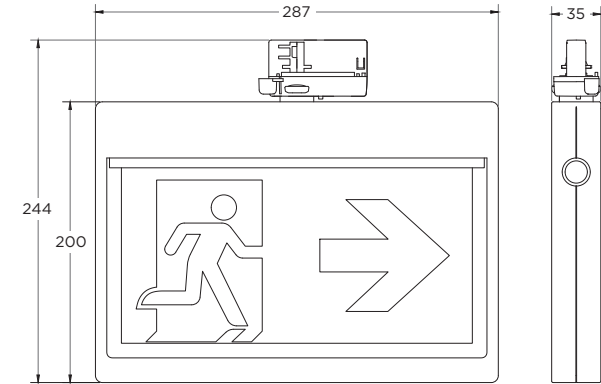

- 230v
- 1.16 KG
- 3hrs
- IP20
- 25m
- DALI
- 6 WARRANTY



EXAMPLE PRODUCT CODE	GO	T	XT	W	IS	D	U
PRODUCT	GO!	GO					
MOUNT	TRACK MOUNTED	T					
CONTROL	DALI MAINTAINED	DL					
	SPECTO-XT MAINTAINED	XT					
COLOUR	WHITE	W					
	BLACK	K					
LEGEND TYPE	ISO 7010	IS					
	BS 5499	BS					
	EC 92/58	EC					
	NO LEGEND	NL					
LEGEND SIDE	SINGLE SIDED	S					
	DOUBLE SIDED	D					
DIRECTION	UP	U					
	DOWN	D					
	RIGHT	R					
	LEFT	L					

GOTXTWISDU GO! Track | Specto-XT Maintained | White finish | ISO 7010 | Double Sided Arrow Up



FEATURES & BENEFITS

- Specto-XT wireless technology removes the need for control cabling, ideal for retro-fit installations
- Class II construction requires no earth for a more cost effective installation
- Hinged battery compartment provides fast battery replacements
- Low power consumption (total 2W/3.9VA)
- Polycarbonate body and tool-less fix legends
- Tool-less second fix body for fast installations