

## FEATURES

Model	Features	Supply voltage	Lumens	Part No.
DALI MAINTAINED	MM3 DALI	220-240V AC 50/60Hz	953 1191 1553	ORADL953 ORADL1191 ORADL1553
SPECTO-XT MAINTAINED	SPECTO XT	220-240V AC 50/60Hz	953 1191 1553	ORAXT953 ORAXT1191 ORAXT1553

## WARNING



Do not stare at operating lamp. It may be harmful to the eyes.

## LUMINAIRE DIMENSIONS

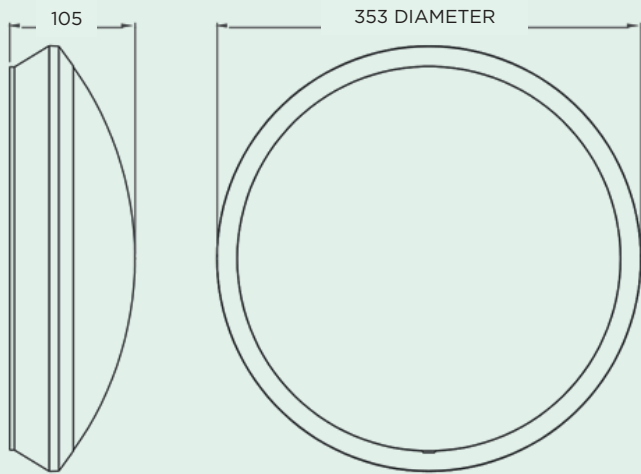

## SUPPLY CONNECTIONS

\*DALI VERSIONS ONLY. (DALI CALBES NOT REQUIRED FOR XT VERSIONS)

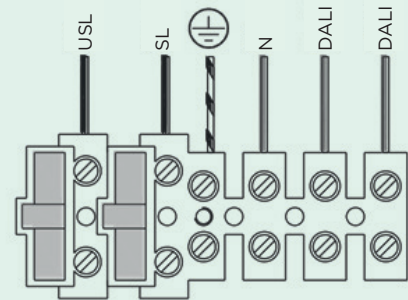

BASIC INSULATION IS MAINTAINED BETWEEN THE LV SUPPLY AND CONTROL CONDUCTORS ON THIS LUMINAIRE.

## INSTALLATION METHOD

1.

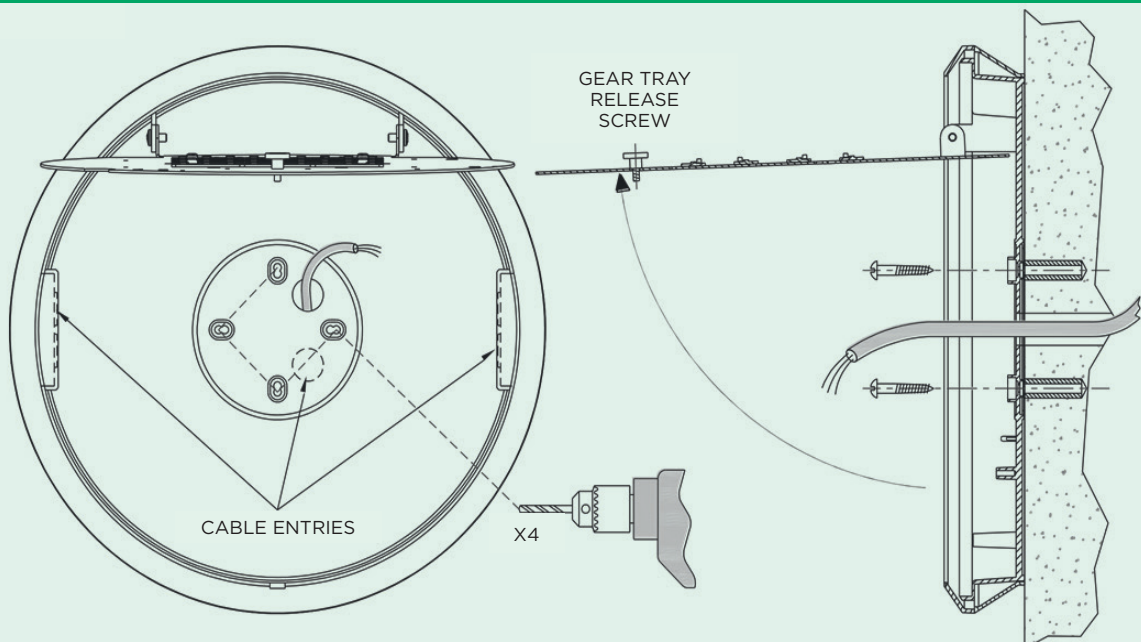

## IMPORTANT-SAFETY

Before carrying out any servicing on this luminaire, ensure that the mains supply is fully isolated. Disconnect luminaire before insulation testing of the installation.

INSTALLATION METHOD

2.

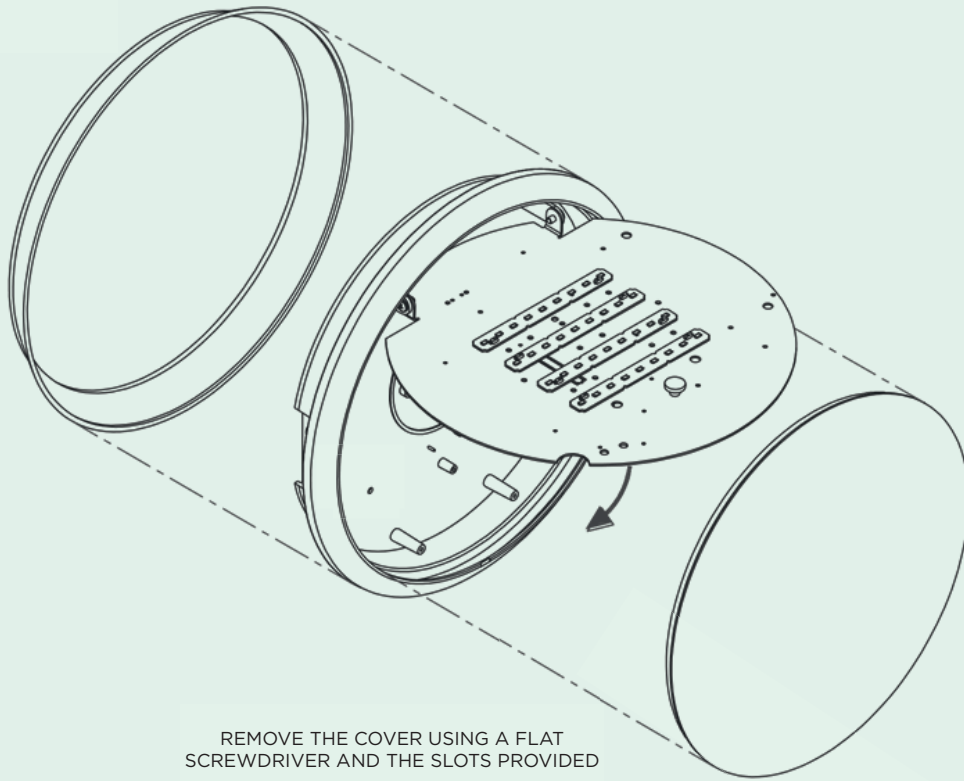

REMOVE THE COVER USING A FLAT SCREWDRIVER AND THE SLOTS PROVIDED

INSTALLATION METHOD- RECESSED OPTION

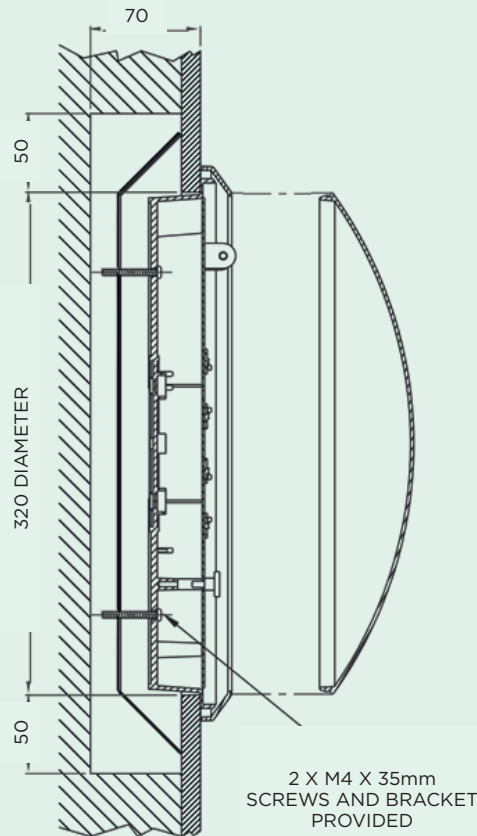

LOOSELY FIX RECESS BRACKET BEFORE INSERTING LUMINAIRE INTO RECESS. THEN TIGHTEN UP THE SCREWS

### LED STATUS INDICATION

Operation	Led Status
Normal mode	Green LED- ON
Commissioning	Green LED- ON
Function test	Green LED- Fast Flash
Duration test	Green LED- Slow flash
Lamp fault/open circuit/short circuit	Red LED - ON
Battery fault	Red LED - Slow flash
Charge fault/Circuit fault	Red LED - Fast flash
Emergency mode	LED OFF
Identification	Red/Green LED - Slow flash

### FAULT RECTIFICATION SEQUENCE

1.Fault Identification	Slow Red Flash = Battery Fault	Permanent Red = Lamp Fault	Charge Fault
2. Take Remedial Action	Check Lamp/ Replace Lamp	Check Battery/ Replace Battery	Check Module/ Replace Module
3. Reset Unit/ Check Status	Switch Luminaire unswitched mains off / on For Specto-XT use the Specto-XT Programmer to check status of luminaire.		
4. Automatic Reset	Philip Payne AutoTest automatically resets the module to confirm rectification of fault. The device then reverts to standby mode if the fault has been cleared or returns to fault indication if fault persists. For Specto-XT use the Specto-XT Programmer to initiate function/duration test. The luminaire will pend the test until the battery is sufficiently charged. The test status can be retrieved using the Specto-XT Programmer (please leave at least 60 seconds between test initiation and reading status).		

### IMPORTANT

To prevent lamp damage and false triggering of fault status please note the following :-

- Ensure LED's are connected correctly to the luminaire prior to applying power.
- Do not interrupt unswitched supply during self-commissioning period.
- Please allow 51 hours for charge, discharge, charge cycle.

Fitting Reference:		Installation Date:										Location:		
MONTH	TEST	EXAMPLE	1ST YEAR	2ND YEAR	3RD YEAR	4TH YEAR	5TH YEAR	6TH YEAR	7TH YEAR	8TH YEAR				
	1. Functional	PASSED												
	2. Functional	PASSED												
	3. Functional	PASSED												
	4. Functional	PASSED												
	5. Functional	PASSED												
	6. Functional	PASSED												
	7. Functional	FAILED- REPLACED LAMP HEAD												
	8. Functional	PASSED												
	9. Functional	PASSED												
	10. Functional	FAILED- REPLACED BATTERY												
	11. Functional	PASSED												
	12. 3-Hour Duration	PASSED												

Each month, or more frequently if a fault is identified, we recommend the installation is checked for status of L.E.D.'s. Corrective action if necessary should be taken and recorded on the above form.

Follow good practice as laid down in relevant legislation such as BS 5266.

TO RESET AFTER A FAULT - SWITCH LUMINAIRE UNSWITCHED  
 MAINS OFF / ON.  
 SLOW RED LED FLASHING = BATTERY FAULT  
 PERMANENT RED LED = LAMP FAULT

**CLEANING INSTRUCTIONS**

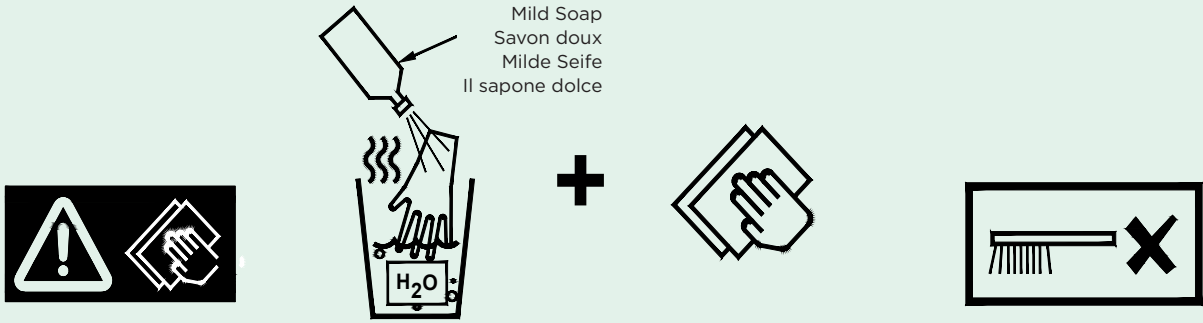

**INFORMATION**

**Operation and Maintenance**

Continual operation at mains voltages in excess of the rated voltage will reduce LED and expected gear life.

This luminaire uses plastic components in its construction and when installed in environments containing chemicals, degradation may occur.

Operation outside intended / stated parameters may cause a hazard, and in an extreme case, for example water ingress to electronic circuits, may cause a fire.

Please contact our Technical Department for advice.

**Modifications**

Philip Payne products should not be modified.

Any modification may render the product unsafe and will invalidate any Safety/Approval marks.

Philip Payne will not accept any responsibility for any modified products or for any damage caused as a result of their modification.

**Monthly and Annual Tests**

Monthly and Annual tests should be carried out in accordance with BS EN 50172:2004, 7.2.

Testing can be carried out by using a sub circuit isolator or by switching off the lighting circuit at the circuit breaker (not for AutoTest or DALI versions).

Battery pack shall be replaced if the specified 3 hour duration is not met.

For replacement battery pack contact Philip Payne Ltd.

The light source contained in this luminaire shall only be replaced by the manufacturer or his service agent or a similar qualified person.



Philip Payne Ltd, Thornhill House, Thornhill Road, Solihull, B91 2HB  
+44 (0)121 705 2384 | mail@philippayne.co.uk | www.philippayne.co.uk

