

Emergency Luminaire Surface Ceiling / Wall

IP65

Class 1



Krona Series

Downlighter features	Supply voltage	Dim 'A'	Dim 'B'	Lumens (mains mode)	Part No.
MM3 SPECTO-XT	220-240V AC 50/60 Hz	105mm	360mm	935 1172 1538	KRONA360XT935 KRONA360XT1172 KRONA360XT1538
		115mm	500mm	1235 1560 2081	KRONA500XT1235 KRONA500XT1560 KRONA500XT2081
MM3 DALI		105mm	360mm	935 1172 1538	KRONA360DL935 KRONA360DL1172 KRONA360DL1538
		115mm	500mm	1235 1560 2081	KRONA500DL1235 KRONA500DL1560 KRONA500DL2081

Dimensions

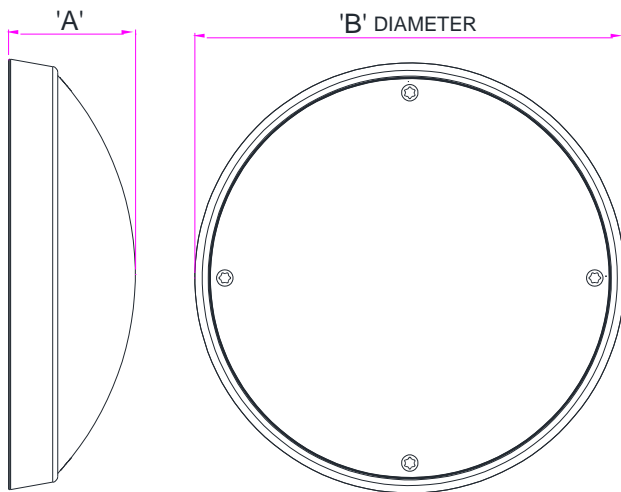

Connections

KRONA360

KRONA500

Basic insulation between L/N and DALI/DALI terminals.

*DALI versions only
(DALI cables not required for Specto XT system).

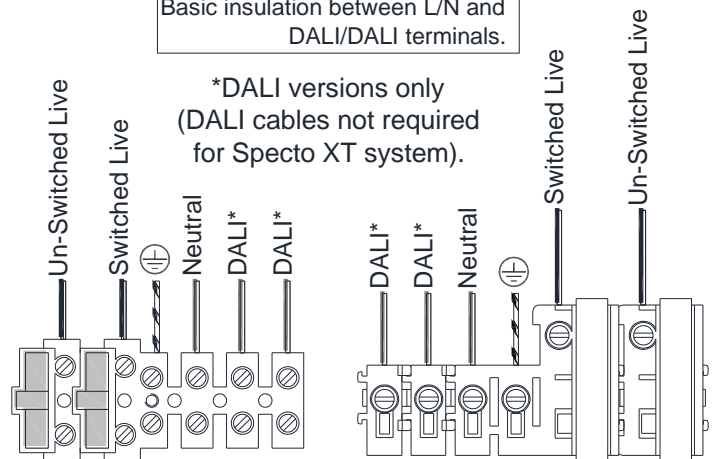

Installation Method

1

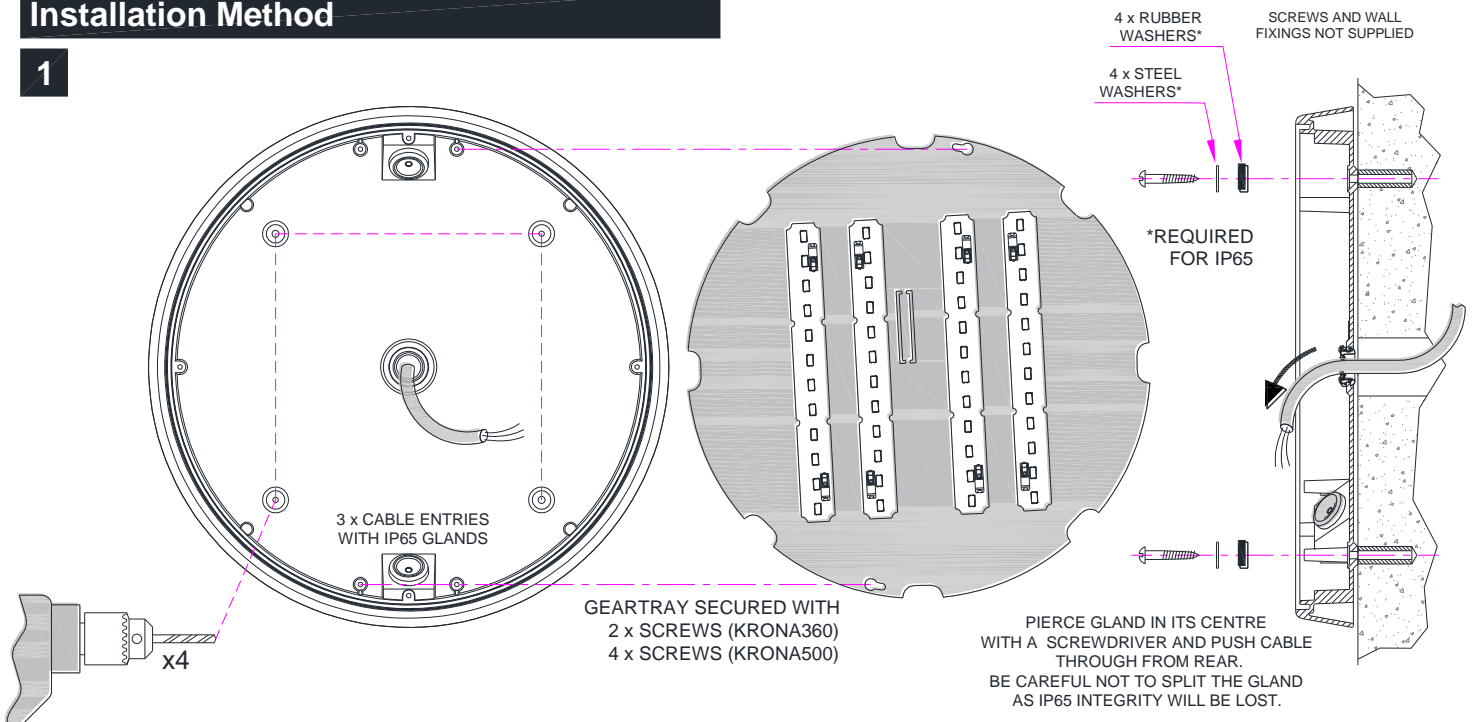

Important-Safety

Before carrying out any servicing on this luminaire, ensure that the mains supply is fully isolated.
Disconnect luminaire before insulation testing of the installation.

2

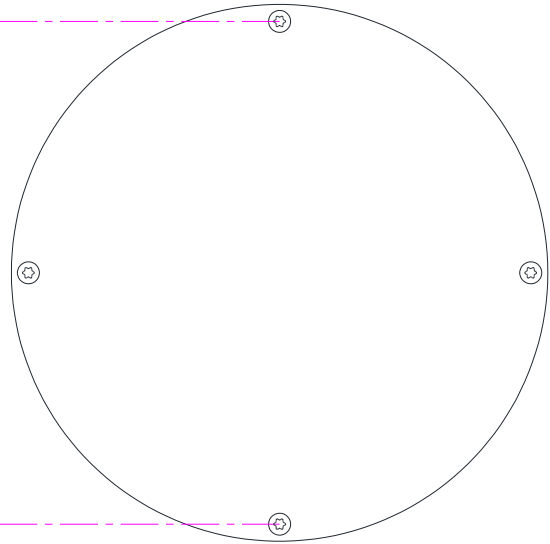
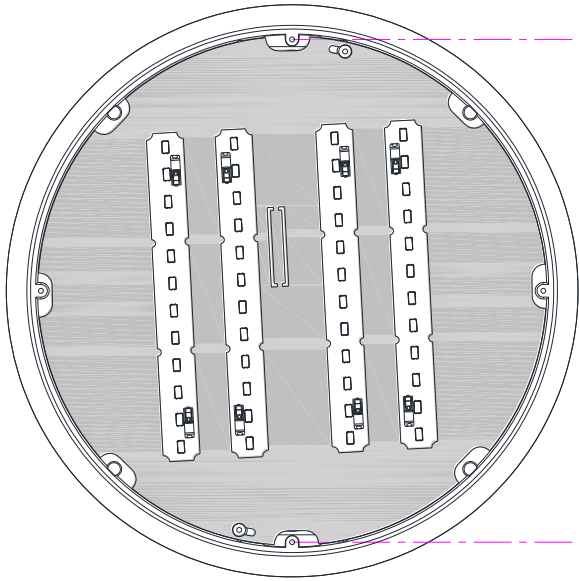

COVER SECURED WITH
4 x SECURITY SCREWS

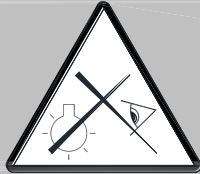

Do not stare at operating LED lightsource.
It may be harmful to the eyes.

Cleaning Instructions

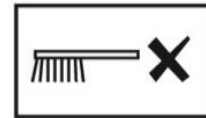

Operation and Maintenance

Continual operation at mains voltages in excess of the rated voltage will reduce LED and expected gear life.

This luminaire uses plastic components in its construction and when installed in environments containing chemicals, degradation may occur.

Please contact our Technical Department for advice.

Modifications

Philip Payne products should not be modified.

Any modification may render the product unsafe and will invalidate any Safety/Approval marks.

Philip Payne will not accept any responsibility for any modified products or for any damage caused as a result of their modification.

Monthly and Annual Tests

Monthly and Annual tests should be carried out in accordance with BS EN 50172:2004, 7.2.

Testing can be carried out by using a sub circuit isolator or by switching off the lighting circuit at the circuit breaker (not for AutoTest or DALI versions).

Battery pack shall be replaced if the specified 3 hour duration is not met.

For replacement battery pack contact Philip Payne Ltd.

The light source contained in this luminaire shall only be replaced by the manufacturer or his service agent or a similar qualified person.

NOTICE TO CONTRACTOR - PLEASE PASS THIS LEAFLET TO THE END-USER.



Philip Payne Ltd

A SUBSIDIARY OF F.W. THORPE PLC
Thornhill Road, Solihull, B91 2HB, England.

Tel: 0121 705 2384

Fax: 0121 711 2469

e-mail: mail@philippayne.co.uk

Website: http://www.philippayne.co.uk

Philip Payne Ltd registered in England No. 1361523



ISO9001
FM55077



21LFT102_2