

- IP20 IK09
- 26m 1.5
- 230v DALI
- NM/MM
- 1W 6 WARRANTY

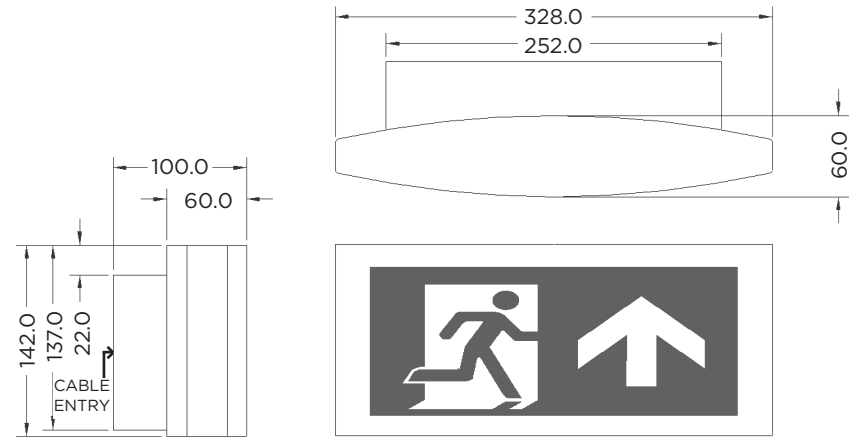

- EN 60598-1
- EN60598-2-22
- EN55015
- EN61547
- EN61000-3-2



EXAMPLE PRODUCT CODE	250	B7	LA	W
FAMILY	250	250		
PRODUCT	B7	B7		
CONTROL GEAR	MAINS/CENTRAL BATTERY*	LA		
	MAINTAINED SELF-CONTAINED	LM		
	MAINTAINED AUTOTEST	YL		
	MAINTAINED DALI	DL		
	MAINTAINED SPECTO-XT	XT		
	GREY	G		
	BLACK	K		
	PENNY BRONZE	V		
	WHITE	W		

Example Code 250B7LAW 250 | B7 | Mains/Central Battery | White

For more information on colours, please go to the **Finishes Page**. For more information on Legends, please go to the **Legends Page**.

*For input voltages please refer to our installation leaflets.