

250MCSH



- IP20 IK09
- 26m KG 1.5
- 230v DALI
- NM/MM
- 1W 6 WARRANTY



- EN 60598-1
- EN60598-2-22
- EN55015
- EN61547
- EN61000-3-2

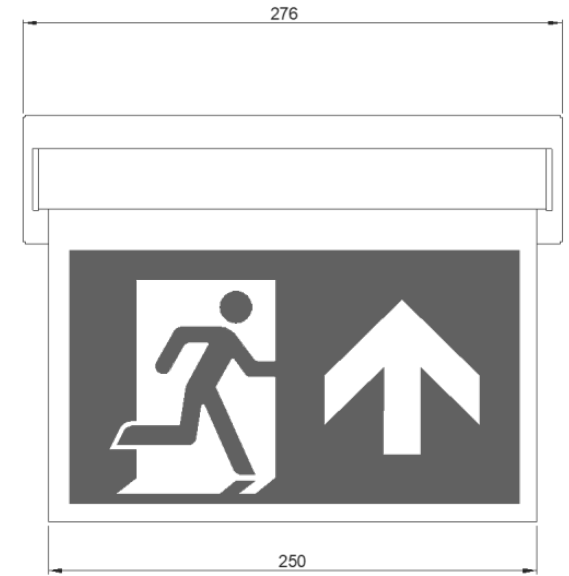
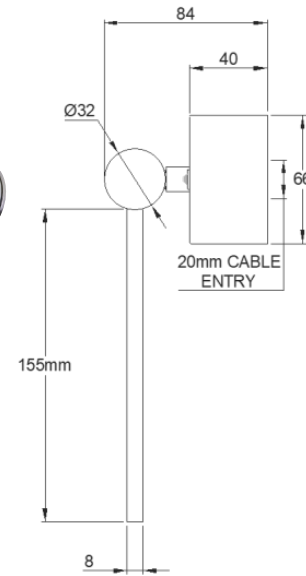

EXAMPLE PRODUCT CODE		250MC	S	H	LM	W
FAMILY	250MC	250MC				
MOUNTING	SURFACE	S				
ORIENTATION	HORIZONTAL	H				
CONTROL GEAR	MAINS/CENTRAL BATTERY*	LA				
	MAINS/CENTRAL BATTERY DALI*	DA				
	MAINTAINED SELF-CONTAINED	LM				
	MAINTAINED AUTOTEST	YL				
	MAINTAINED DALI	DL				
	MAINTAINED SPECTO-XT**	XT				
COLOUR	POLISHED BRASS	B				
	POLISHED CHROME	C				
	ANTIQUE BRASS	E				
	GREY	G				
	BLACK	K				
	SATIN CHROME	R				
	PENNY BRONZE	V				
	WHITE	W				

Example Code 250MCSHLMW 250MC | Surface | Horizontal | Maintained Self Contained | White Finish

For more information on colours, please go to the **Finishes Page**. For more information on Legends, please go to the **Legends Page**.

*For input voltages please refer to our installation leaflets.

**Only available in White, Grey, Black, Satin chrome and Penny Bronze finish