

Edgelit Exit Sign IP20 Class 1 CE Surface Ceiling 250CM

		230V	250CMLA 250CMLE
	DALI	230V	250CMDA
	MM3	MM3	250CMLM
	AutoTest	MM3	250CMYL
	DALI	MM3	250CMDL
	SpectoXT	MM3	250CMXT

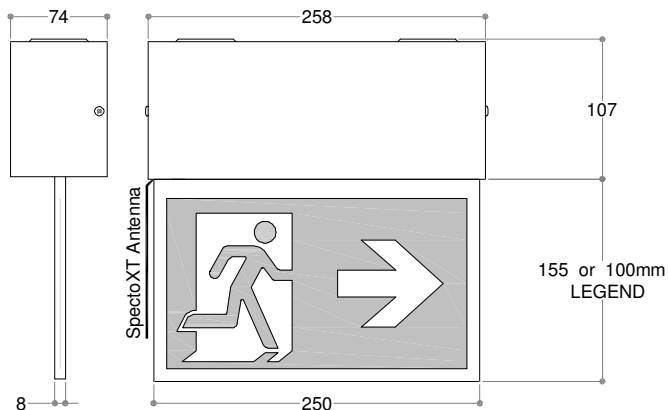

Monthly and Annual tests should be carried out in accordance with: BS EN 50172:2004, 7.2.

Testing can be carried out by using a sub circuit isolator or by switching off the lighting circuit at the circuit breaker. (Not for Autotest or Dali versions.)

Battery Pack shall be replaced if the specified 3 hour duration is not met.

For replacement LED strip contact Philip Payne Ltd.

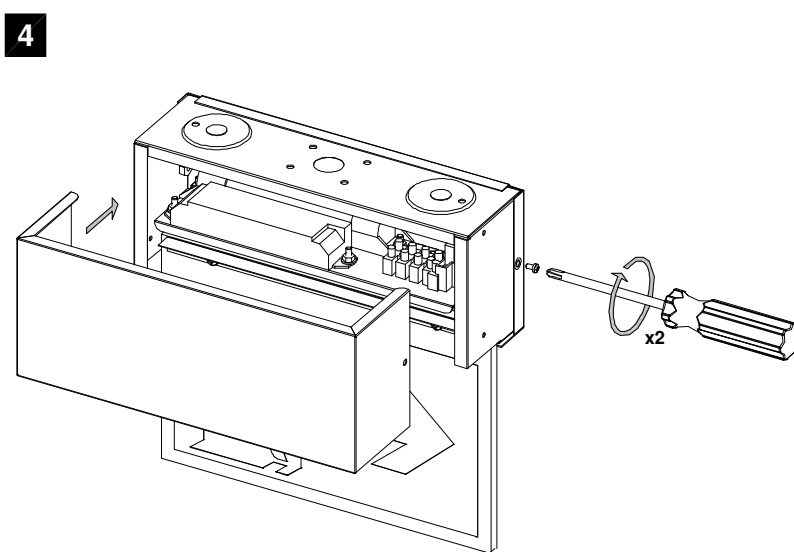
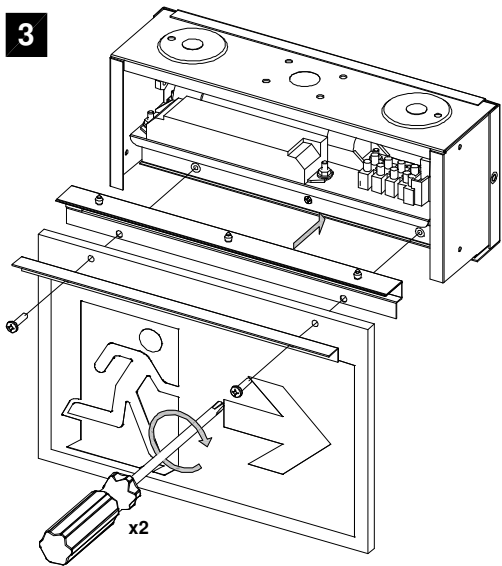
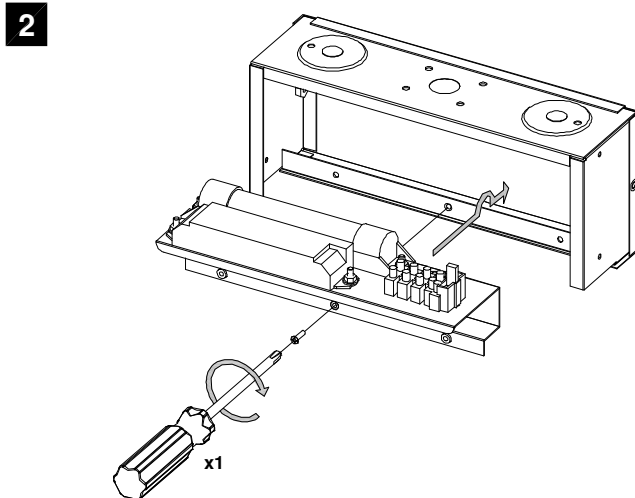
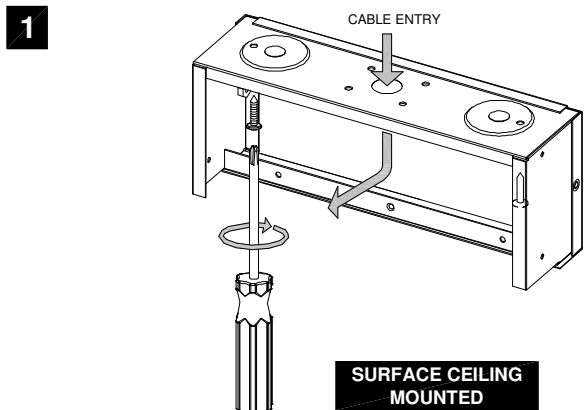
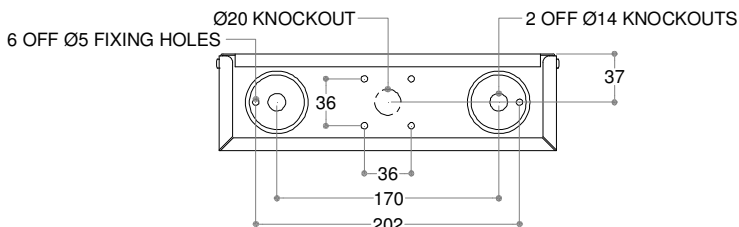

Connections - Connexions - Conexiones

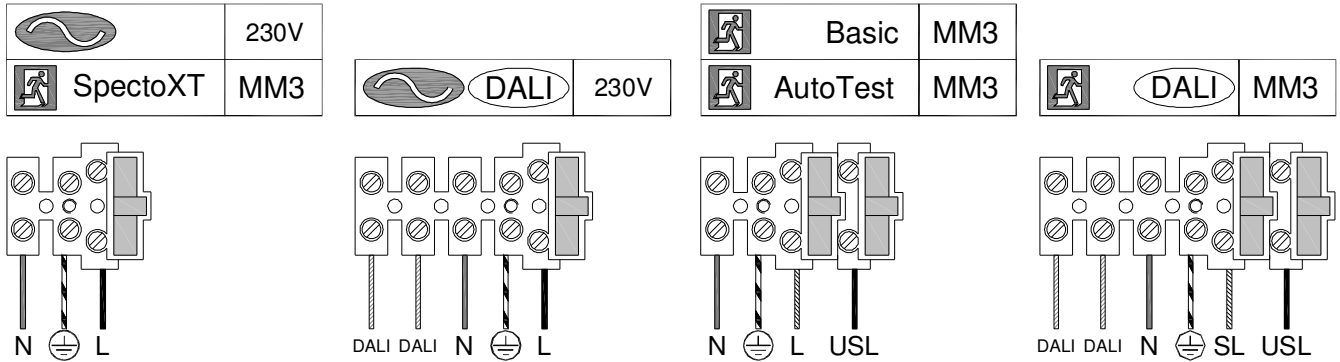

<p>Operation and Maintenance The 250CM uses plastic components in its construction and when installed in environments containing chemicals, degradation may occur. Please contact our Technical Department for advice.</p> <p>Modifications Philip Payne products should not be modified. Any modification may render the product unsafe and will invalidate any Safety/Approval marks. Philip Payne will not accept any responsibility for any modified products or for any damage caused as a result of their modification.</p>	<p>Fonctionnement et Maintenance Des composants en plastique ont été intégrés dans la construction du 250CM, et une certaine détérioration peut survenir lorsqu'il est installé dans des environnements contenant des produits chimiques. Veuillez contacter notre Département Technique pour obtenir de plus amples informations.</p> <p>Modifications Les produits Philip Payne ne doivent pas être modifiés. Toute modification peut compromettre la sécurité du produit et annuler les marques de sécurité / homologation. Philip Payne refusera toute responsabilité pour des produits modifiés ou pour tout dommage entraîné par une modification.</p>	<p>Betrieb und Wartung 250CM-Produkte enthalten Kunststoffteile; bei einer Installation in Umgebungen, die Chemikalien enthalten, ist ein Qualitätsverlust nicht auszuschließen. Unsere Technische Abteilung berät Sie gerne.</p> <p>Änderungen Philip Payne-Produkte sollten nicht geändert werden. Jegliche Änderungen können die Produktsicherheit beeinträchtigen und machen Sicherheits-/Genehmigungskennzeichnungen ungültig. Philip Payne übernimmt keine Verantwortung für modifizierte Produkte bzw. Für Schäden, die durch Produktänderungen verursacht werden.</p>	<p>Funzionamento e manutenzione Il 250CM è stato costruito con componenti di plastica e, se installato in ambienti che contengono sostanze chimiche, si può notare un degradamento. Per ulteriori consigli si prega di contattare il nostro reparto tecnico.</p> <p>Modifiche I prodotti Philip Payne non devono essere modificati, dato che qualsiasi modifica potrebbe rendere il prodotto insicuro e invalidare ogni segno di sicurezza/approvazione. Philip Payne non accetta nessuna responsabilità per prodotti modificati e per danni causati quale risultato delle modifiche apportate agli stessi.</p>
---	--	---	---

<p>Important-Safety Before carrying out any servicing on this luminaire, ensure that the mains supply is fully isolated. Disconnect luminaire before insulation testing of the installation.</p>	<p>Important-Sécurité Avant d'effectuer des réparations sur ce luminaire, vérifiez que l'alimentation secteur est coupée. Débranchez le luminaire avant d'effectuer un essai d'isolement de l'installation.</p>	<p>Wichtiger Sicherheitshinweis Stellen Sie vor Durchführen von Wartungsarbeiten an diesem Beleuchtungskörper sicher, dass die Netzstromversorgung vollständig isoliert ist. Trennen Sie den Beleuchtungskörper von der Stromversorgung, bevor Sie die Isolierung der Anlage testen.</p>	<p>Importante - Sicurezza Prima di eseguire la manutenzione, assicurarsi chela rete elettrica sia completamente isolata. Scollegare il prodotto prima di eseguire il test d'isolamento dell'installazione.</p>
---	--	---	---



Philip Payne Ltd
A SUBSIDIARY OF F.W. THORPE PLC
Thornhill Road, Solihull, B91 2HB, England.
Tel: 0121 705 2384
Fax: 0121 711 2469
e-mail: mail@philippayne.co.uk
Website: http://www.philippayne.co.uk
Philip Payne Ltd registered in England No. 1361523



ISO9001
FM55077



21LFT024_3