

# 250FC/300FC

Edgelit Sign

CE IP20

Earthing Class I

Installation Instructions ■ Instructions de Montage ■ Montageanweisung ■ Istruzioni di Montaggio

Installation Leaflet

LED

	230V	250FCLA 250FCLE
DALI	230V	250FCDA
MM3	MM3	250FCLM
AutoTest	MM3	250FCYL
DALI	MM3	250FCDL
SpectoXT	MM3	250FCXT

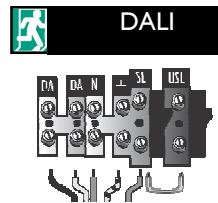
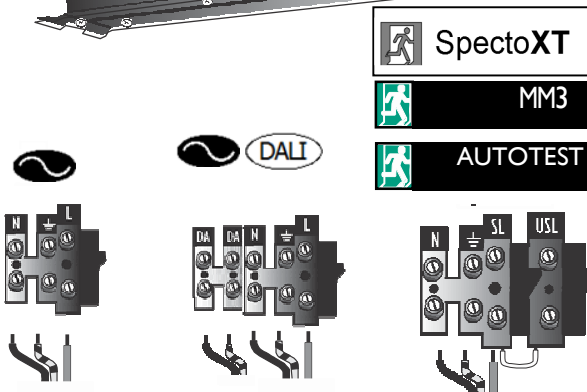
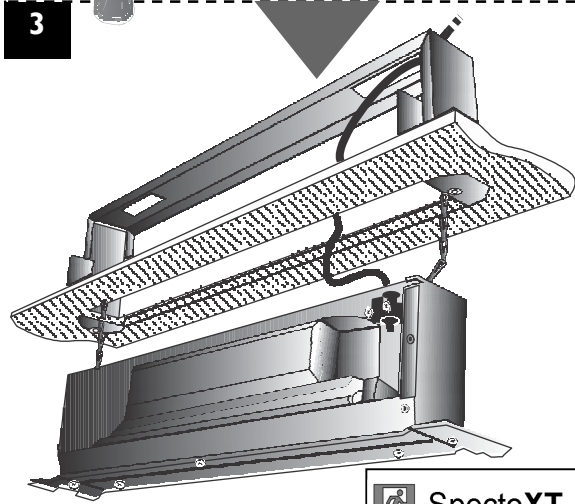
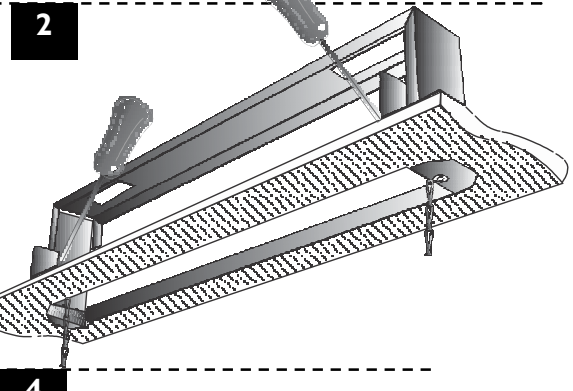
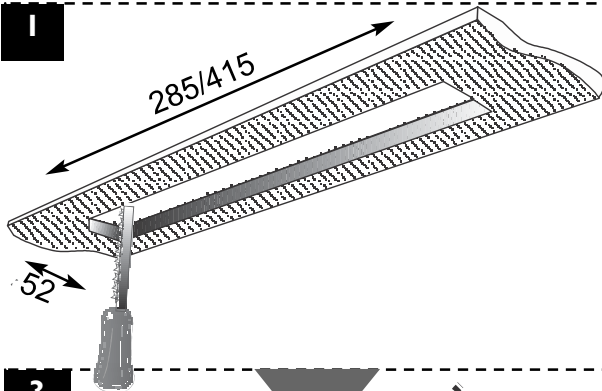
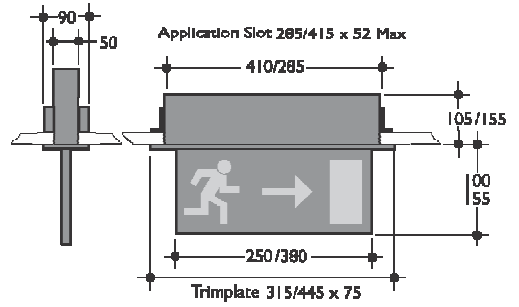

Basic Insulation between L/N and DALI Terminals.



5

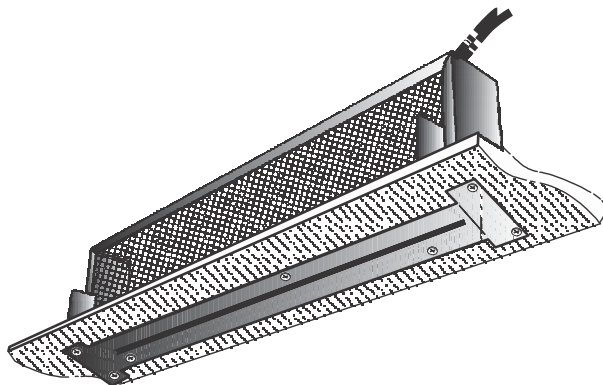

Monthly and Annual tests should be carried out in accordance with: BS EN 50172:2004, 7.2.

Testing can be carried out by using a sub circuit isolator or by switching off the lighting circuit at the circuit breaker. (Not for AutoTest or Dali versions.)

The light source contained in this luminaire shall only be replaced by the manufacturer or his service agent or a similar qualified person.

Battery Pack shall be replaced if the specified 3 hour duration is not met.

6

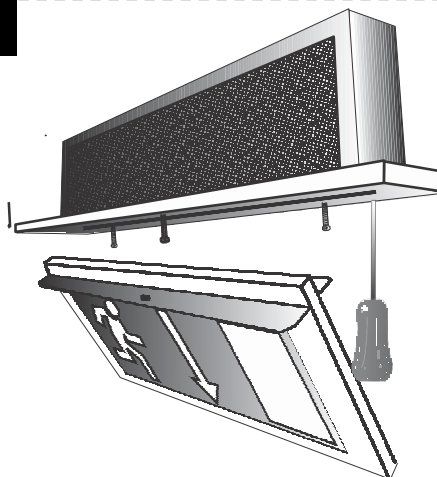

7

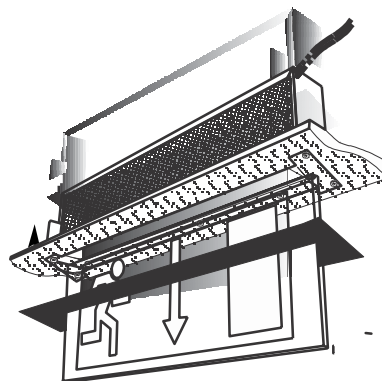

+



**Operation and Maintenance**

Failed lamps should be replaced promptly or the circuit switched off to avoid possible damage to control gear. Continual operation at mains voltages in excess of the rated voltage will reduce lamp and expected gear life.

The 250FC/300FC uses plastic components in its construction and when installed in environments containing chemicals, degradation may occur. Please contact our Technical Department for advice.

**Modifications**

Philip Payne products should not be modified. Any modification may render the product unsafe and will invalidate any Safety/Approval marks. Philip Payne will not accept responsibility for any modified products or for any damage caused as a result of their modification.

**Fonctionnement et Maintenance**

Les lampes défectueuses doivent être changées rapidement ou le circuit doit être coupé pour éviter tout risque d'endommagement de l'appareil de commande. Un fonctionnement continu à des tensions secteur dépassant la tension nominale réduira la durée de vie prévue de la lampe et de l'appareil de commande.

Des composants en plastique ont été intégrés dans la construction du 250FC/300FC et une certaine détérioration peut survenir lorsqu'il est installé dans des environnements contenant des produits chimiques. Veuillez contacter notre Département Technique pour obtenir de plus amples informations.

**Modifications**

Les produits Philip Payne ne doivent pas être modifiés. Toute modification peut compromettre la sécurité du produit et annuler les marques de sécurité / homologation. Philip Payne refusera toute responsabilité pour des produits modifiés ou pour tout dommage entraîné par une modification.

**Betrieb und Wartung**

Um eine Beschädigung des Vorschaltgeräts zu vermeiden, sollten defekte Lampen unverzüglich ausgewechselt oder der Stromkreis unterbrochen werden. Bei fortlaufendem Betrieb mit einer Netzspannung, die die Nennspannung übersteigt, nimmt die erwartete Lebensdauer der Lampe und des Geräts ab.

250FC/300FC-Produkte enthalten Kunststoffteile; bei einer Installation in Umgebungen, die Chemikalien enthalten, ist ein Qualitätsverlust nicht auszuschließen. Unsere Technische Abteilung berät Sie gerne.

**Änderungen**

Philip Payne-Produkte sollten nicht geändert werden. Jegliche Änderungen können die Produktsicherheit beeinträchtigen und machen Sicherheits-/Genehmigungskennzeichnungen ungültig. Philip Payne übernimmt keine Verantwortung für modifizierte Produkte bzw. für Schäden, die durch Produktänderungen verursacht werden.

**Funzionamento e manutenzione**

Quando le lampadine si guastano, sostituirle immediatamente oppure spegnere il circuito per evitare danni possibili all'ingranaggio di comando. Una tensione continuamente in eccesso di quella stipulata farà ridurre l'anticipata vita della lampadina e dell'ingranaggio.

Il 250FC/300FC è stato costruito con componenti di plastica e, se installato in ambienti che contengono sostanze chimiche, si può notare un deperimento. Per ulteriori consigli si prega di contattare il nostro reparto tecnico.

**Modifiche**

I prodotti Philip Payne non devono essere modificati, dato che qualsiasi modifica potrebbe rendere il prodotto insicuro e invalidare ogni segno di sicurezza/approvazione. Philip Payne non accetta nessuna responsabilità per prodotti modificati e per danni causati quale risultato delle modifiche apportate agli stessi.

**Important-Safety**

Before carrying out any servicing on this luminaire, ensure that the mains supply is fully isolated.

Disconnect luminaire before insulation testing of the installation.

**Important-Sécurité**

Avant d'effectuer des réparations sur ce luminaire, vérifiez que l'alimentation secteur est coupée.

Débranchez le luminaire avant d'effectuer un essai d'isolement de l'installation.

**Wichtiger Sicherheitshinweis**

Stellen Sie vor Durchführen von Wartungsarbeiten an diesem Beleuchtungskörper sicher, dass die Netzstromversorgung vollständig isoliert ist.

Trennen Sie den Beleuchtungskörper von der Stromversorgung, bevor Sie die Isolierung der Anlage testen.

**Importante - Sicurezza**

Prima di eseguire la manutenzione, assicurarsi chela rete elettrica sia completamente isolata.

Scogliere il prodotto prima di eseguire il test d'isolamento dell'installazione.

Leaflet number: 21LFT1013\_5

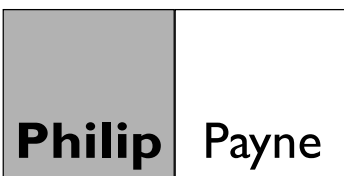

**Philip Payne Ltd**

A SUBSIDIARY OF F.W. THORPE PLC

Thornhill Road, Lode Lane, Solihull, B91 2HB, England.

Tel: 0121 705 2384

Fax: 0121 711 2469

E-mail: [mail@philippayne.co.uk](mailto:mail@philippayne.co.uk)

Website: [www.philippayne.co.uk](http://www.philippayne.co.uk)

Philip Payne Ltd registered in England No. 1361523

We reserve the right to alter specifications without prior notice.



ISO 9001  
FM55077

