

FEATURES	SUPPLY VOLTAGE	MAXIMUM LOADING OF AUTOMATIC CIRCUIT BREAKER TYPE B 10A. INSTALLATION Ø 1.5mm ²	Part No.
NM3	220-240V AC 50/60 Hz	90 LUMINAIRES	250FBLM
NM3 AutoTest	220-240V AC 50/60 Hz	90 LUMINAIRES	250FBYL
NM3	220-240V AC 50/60 Hz	90 LUMINAIRES	250FBDL
	220-240V DC/AC 50/60 Hz	30 LUMINAIRES	250FBLA
	220-240V DC/AC 50/60 Hz	30 LUMINAIRES	250FBDA

WARNING

DO NOT STARE AT OPERATING LAMP. IT MAY BE HARMFUL TO THE EYES.

DIMENSIONS

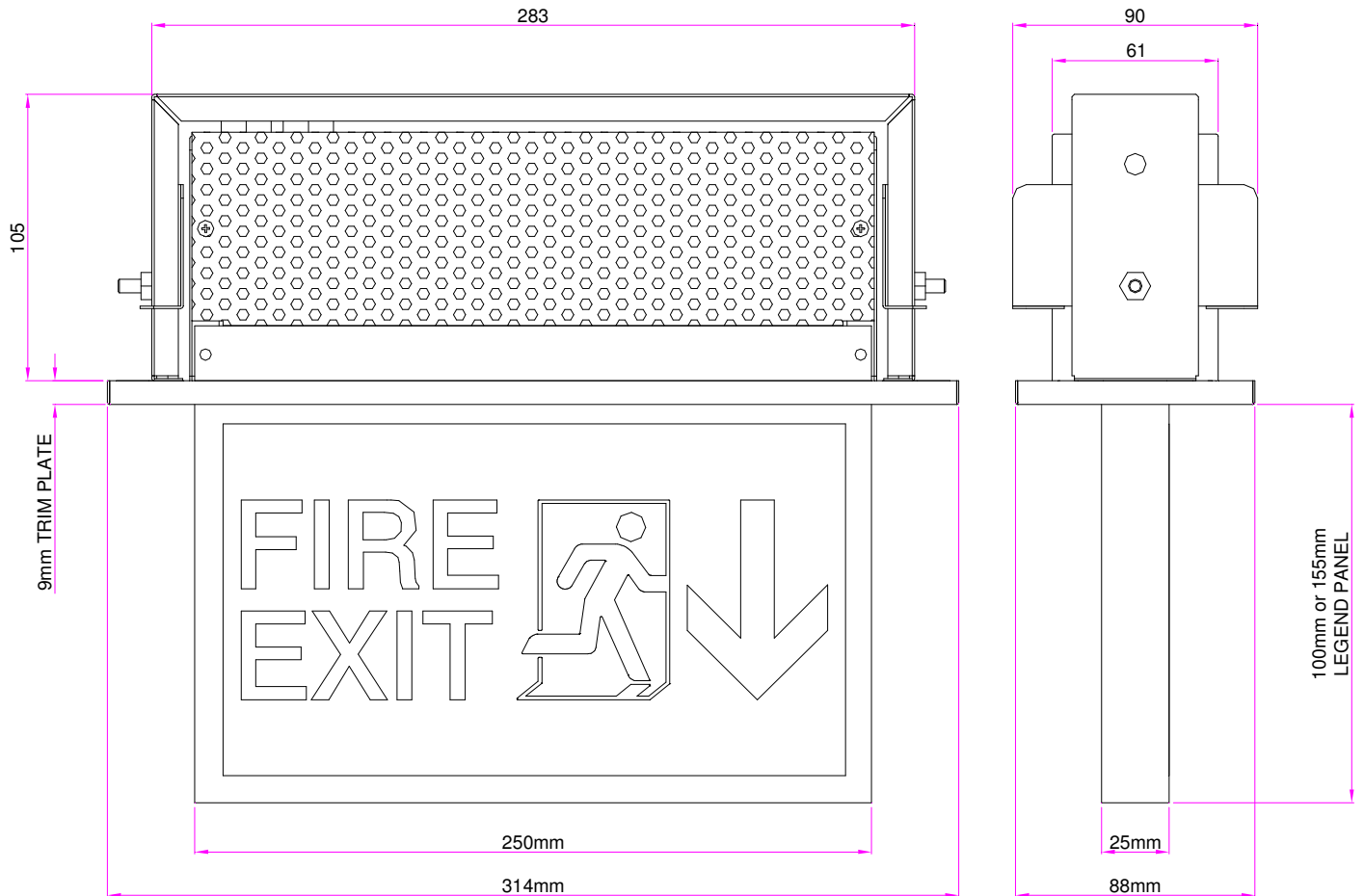

IMPORTANT SAFETY
 BEFORE CARRYING OUT ANY SERVICING ON THIS LUMINAIRE, ENSURE THAT THE MAINS SUPPLY IS FULLY ISOLATED.

NOTICE TO CONTRACTOR - PLEASE PASS THIS LEAFLET TO THE END USER.

INSTALLATION METHOD

1.

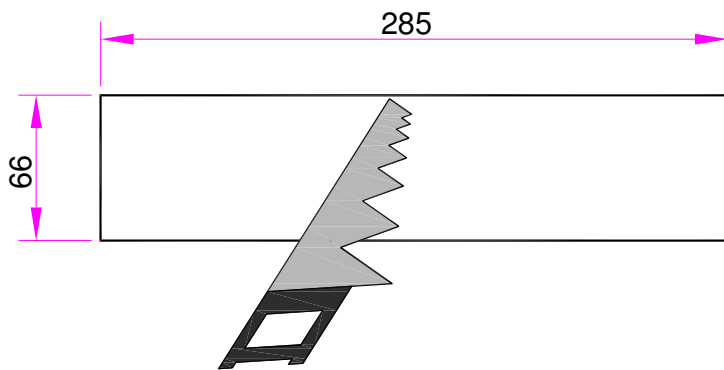

2.

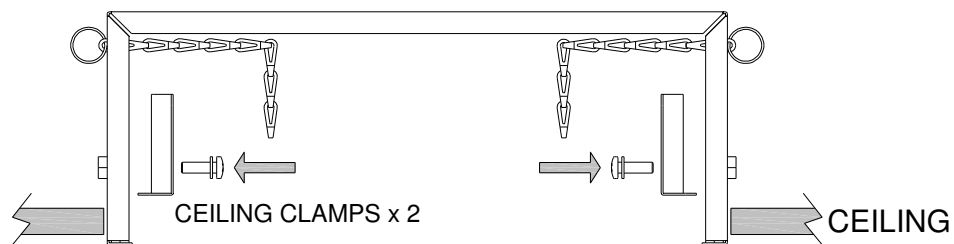

3.

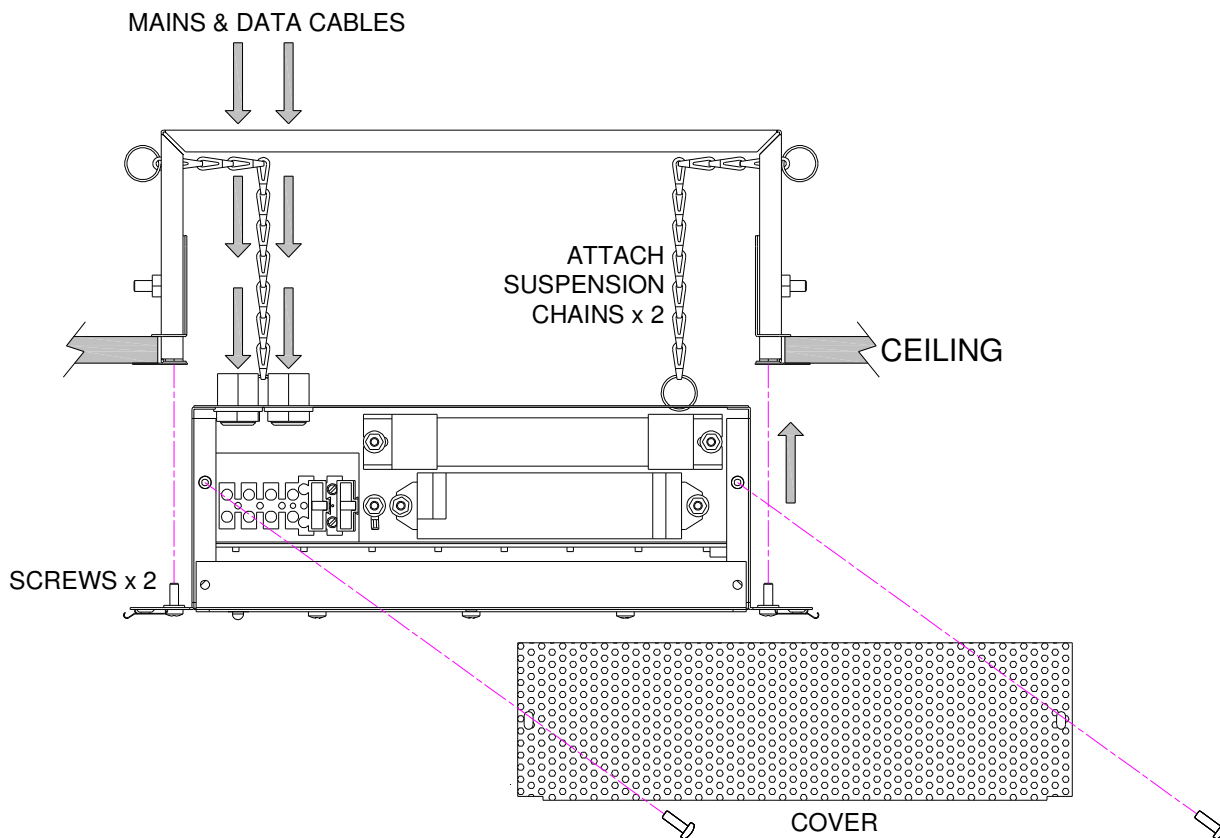

CONNECTIONS

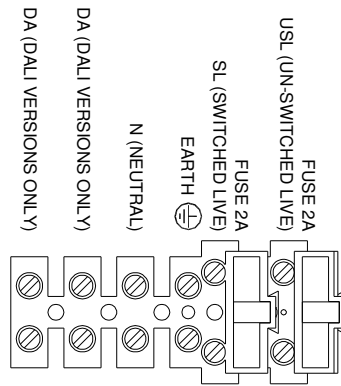

4.

LEGEND PANEL & BRACKET ASSEMBLY

2 x SCREWS



2 x BRACKETS

LEGEND PANEL

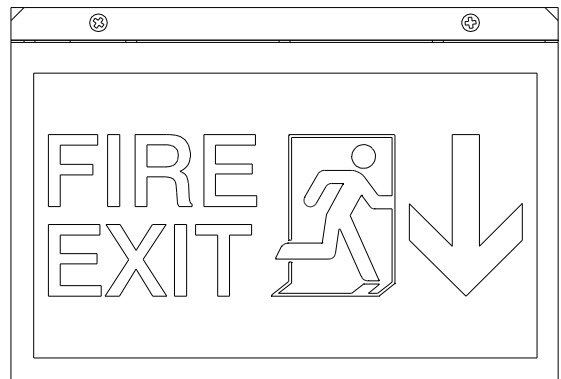

5.

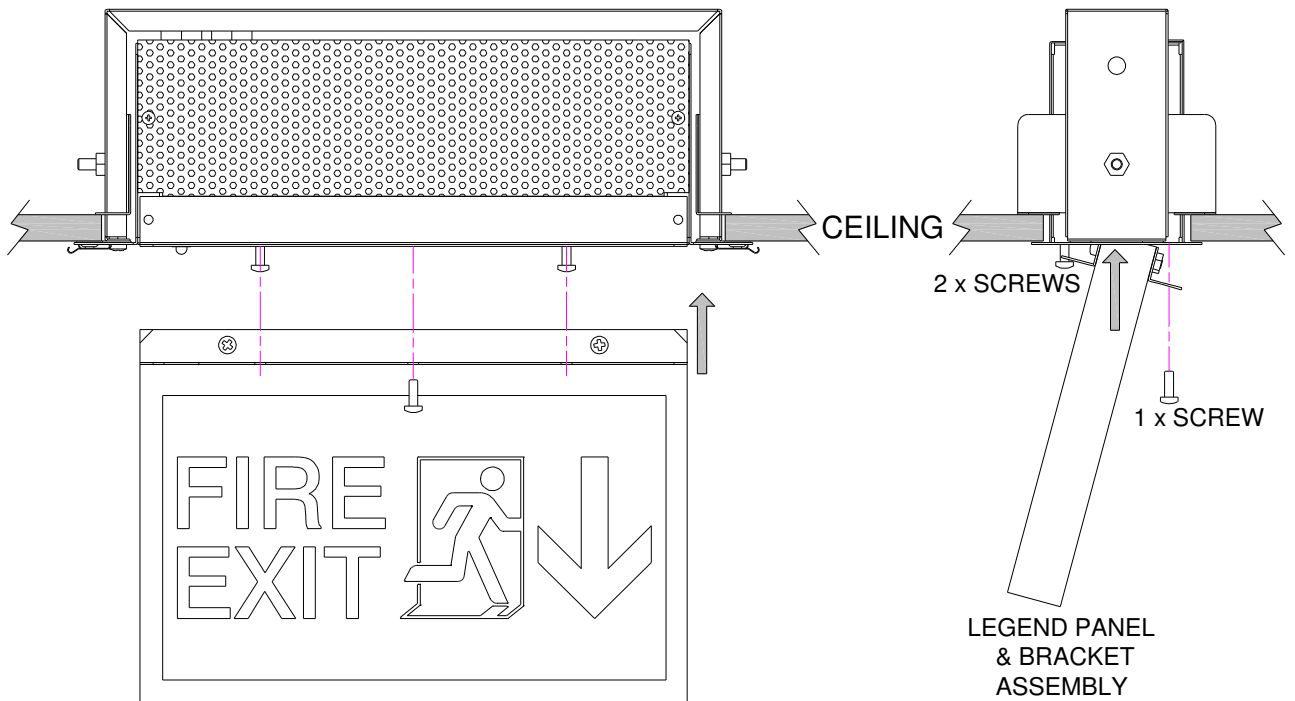

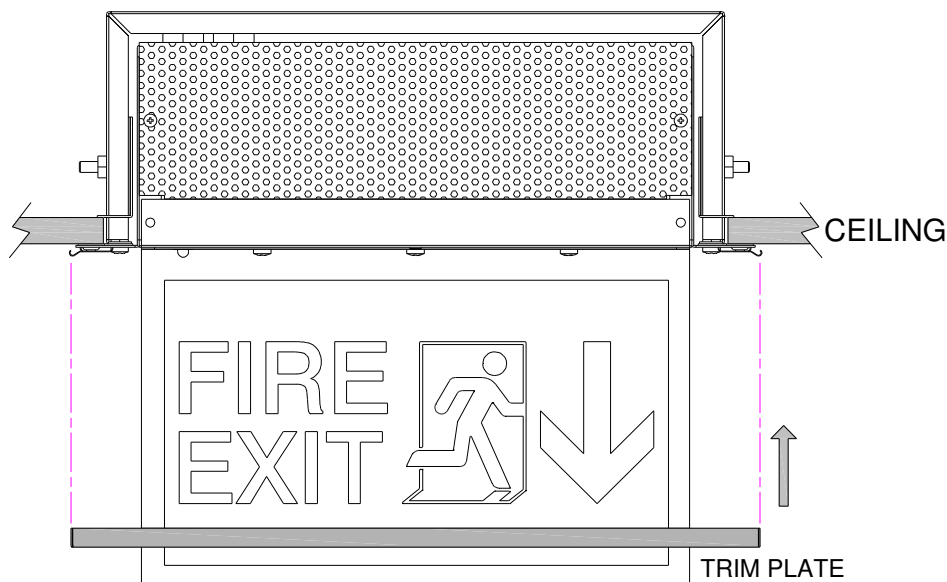

Cleaning Instructions



Operation and Maintenance

Continual operation at mains voltages in excess of the rated voltage will reduce LED and expected gear life.

This luminaire uses plastic components in its construction and when installed in environments containing chemicals, degradation may occur. Please contact our Technical Department for advice.

Modifications

Philip Payne products should not be modified.

Any modification may render the product unsafe and will invalidate any Safety/Approval marks.

Philip Payne will not accept any responsibility for any modified products or for any damage caused as a result of their modification.

Monthly and Annual Tests

Monthly and Annual tests should be carried out in accordance with BS EN 50172:2004, 7.2.

Testing can be carried out by using a sub circuit isolator or by switching off the lighting circuit at the circuit breaker (not for AutoTest or DALI versions).

Battery pack shall be replaced if the specified 3 hour duration is not met.

For replacement battery pack contact Philip Payne Ltd.

The light source of this luminaire is not replaceable; when the light source reaches its end of life the whole luminaire shall be replaced.



Philip Payne Ltd

A SUBSIDIARY OF F.W. THORPE PLC
Thornhill Road, Solihull, B91 2HB, England.

Tel: 0121 705 2384
Fax: 0121 711 2469
e-mail: mail@philippayne.co.uk
Website: http://www.philippayne.co.uk
Philip Payne Ltd registered in England No. 1361523



ISO9001
FM55077



21LFT088_1